

NR-DVR400-N
Power Supply Product Specification

NegoRack®

SPECIFICATION

Model Name: NR-DVR400-N

Rev:	Description	Author / Editor	Date
1.0	Initial Engineering Specification	Gilbert Lin	2015-02-05
1.1	1. Improve the efficiency from Bronze Level to Sliver Level 2. Add 3C 5000 Meter Standard	Gilbert Lin	2015-06-10
1.2	1. 5VSB Ripple Noise Modify to 60Mv 2. Modify Inrush Current Spec.	Gilbert Lin	2015-07-01
1.3	Modify Tvout & Tpwok holdup time	Gilbert Lin	2015-07-06
1.4	Modify 5v & 3.3v Output Rating	Gilbert Lin	2015-08-28
1.5	Update safety requirements	Gilbert Lin	2015-09-08
1.6	Update CCC Certificate to 5000M	Hannah Lai	2015-12-01
1.7	Update 5. Environmental Requirements 5.6 Electromagnetic Compatibility EMC Requirements	Hannah Lai	2016-02-03

Design			Product Verification	
Mechanical	Electrical	Approval	Safety	Approval

	Model No.:	NR-DVR400-N	Product Specification
	NegoRack LTD		Document No.:

1. Purpose

This specification defines the performance characteristics and functions of a 400 watts 2U form factor of power supply with Active PFC (Power Factor Correction) and PMBus (Power Management Bus).

2. Input Requirements

2.1 Input Rating

The power supply must operate within all specified limits under the rated input voltage range, shown in below table. The AC line inrush current shall not damage any component nor cause the AC line fuse to blow under any DC conditions and with any specified AC line input voltage and frequency. Inrush current is tested at 25 °C ambient and cold start within 1/4 AC cycle. Repetitive On/Off cycling of the AC input voltage shall not damage the power supply.

Table 1: Input Rating

Parameter	Minimum (Vac)	Rated (Vac)	Maximum (Vac)	Max. Current (A)	
				400W	300W
Input Voltage	90 V	100-240V	264 V	5.0~2.5	4.0~2.0
Input Frequency	47 Hz	50 / 60	63 Hz	-	-

Note: 1. The charging current for X capacitors is not considered as in-rush current

2.2 AC Line Transient Specification

AC line transient conditions are characterized as “sag” and “surge” conditions. Sag conditions (also referred to as “brownout” conditions) will be defined as the AC line voltage dropping below nominal voltage. Surge conditions will be defined as the AC line voltage rising above nominal voltage. The power supply shall meet the regulation requirements under the following AC line sag and surge conditions.

Table 2: AC Line Sag Transient Performance

Duration	Sag	Operating AC Voltage	Line Frequency	Load	Performance Criteria
Continuous	10%	230/115VAC	50/60 Hz	100%	No loss of function or performance
0-1/2 AC cycle	30%	230/115VAC	50/60 Hz	70%	No loss of function or performance
> 1/2 AC cycle	> 30%	230/115VAC	50/60 Hz	70%	Loss of function Acceptable Self-recoverable

 NegoRack LTD	Model No.:	Product Specification
	NR-DVR400-N	Document No.:

Table 3: AC Line Surge Transient Performance

Duration	Surge	Operating AC Voltage	Line Frequency	Load	Performance Criteria
Continuous	10%	230/115VAC	50/60 Hz	100%	No loss of function or performance
0 - ½ AC cycle	30%	230/115VAC	50/60 Hz	100%	No loss of function or performance
> 1/2 AC cycle	> 30%	230/115VAC	50/60 Hz	100%	Loss of function Acceptable Self-recoverable

3. DC Output Specification

3.1 Output Power / Currents

Table 4: Load Range (400W)

Voltage	Minimum Load	Maximum Continuous Load
+3.3V	0.5A	20A
+5V	0.5A	20A
+12V	1A	32A
-12V	0A	0.5A
+5VSB	0.1A	2.5A

Note1. : Total output of 3.3V and 5V shall not exceed 140W

Note2. : Total output shall not exceed 400W

Note3: Operating Ambient, normal mode: 0°C ~ 40°C

Table 4-1: Load Range(300W)

Voltage	Minimum Load	Maximum Continuous Load
+3.3V	0.5A	20A
+5V	0.5A	20A
+12V	1.0A	24A
-12V	0A	0.5A
+5VSB	0.1A	2.5A

Note1. : Total output of 3.3V and 5V shall not exceed 140W

Note2. : Total output shall not exceed 300W

	Model No.:	Product Specification
	NR-DVR400-N	Document No.:
NegoRack LTD		

Note3: Operating Ambient, normal mode : 0°C ~ 50°C

3.2 Voltage Regulation, Ripple and Noise

Table 5: Regulation, ripple and noise

Output Voltage	+3.3V	+5V	+12V	-12V	5VSB
Load Reg.	±5%	±5%	±5%	±10%	±5%
Line Reg.	±1%	±1%	±1%	±1%	±1%
Ripple & Noise	50mV	50mV	120mV	120mV	60mV

Ripple and noise shall be measured using the following methods:

- Measurements made differentially to eliminate common-mode noise
- Ground lead length of oscilloscope probe shall be ≤ 0.25 inch.
- Measurements made where the cable connectors attach to the load.
- Outputs bypassed at the point of measurement with a parallel combination of 10uF tantalum capacitor in parallel with 0.1uF ceramic capacitors.
- Oscilloscope bandwidth of 0 Hz to 20MHz.
- Measurements measured at locations where remote sense wires are connected.
- Regulation tolerance shall include temperature change, warm up drift and dynamic load

3.3 Capacitive Loading

The power supply shall be stable and meet all requirements in the following table, except dynamic loading requirements.

Table 6: Capacitive Loading Conditions

Output	MIN	MAX	Units
+3.3V, +5V, +12V	1000	11,000	uF
5VSB	1	500	uF

3.4 Dynamic Loading

The output voltages shall remain within the limits specified in *Table-Regulation, ripple and noise* for the step loading and within the limits specified in *Table-Transient Load Requirement* for the capacitive loading. The load transient repetition rate shall be tested between **50Hz and 5kHz** at duty cycle ranging from 10%-90%. The load transient repetition rate is only a test specification. The Δ step load may occur anywhere within the MIN load to the MAX load shown in *Table-Load Range*.

Table 7: Transient Load Requirements

Output	ΔStep Load Size	Load Slew Rate	Capacitive Load
+12v	50% of Max. Load	0.5 A/uS	2200 uF
+3.3V, +5V	30% of Max. Load	0.5 A/uS	2200 uF

	Model No.:	Product Specification
	NR-DVR400-N	
NegoRack LTD		Document No.:

5VSB	0.5A	0.5 A/uS	20 uF
------	------	----------	-------

3.5 Closed Loop Stability

The power supply shall be stable under all load conditions. A minimum of 40degrees phase margin and 4dB gain margin is required.

3.6 Overshoot at Turn-on/Turn-off

Any output overshoot at turn on shall be less than 10% of the nominal output value. Any overshoot shall recover to be within regulation requirements in less than 10ms.

	Model No.:	Product Specification
	NR-DVR400-N	Document No.:
NegoRack LTD		

Figure 1: Output Voltage Timing



3.7 Timing Requirements

AC turn On/off cycle

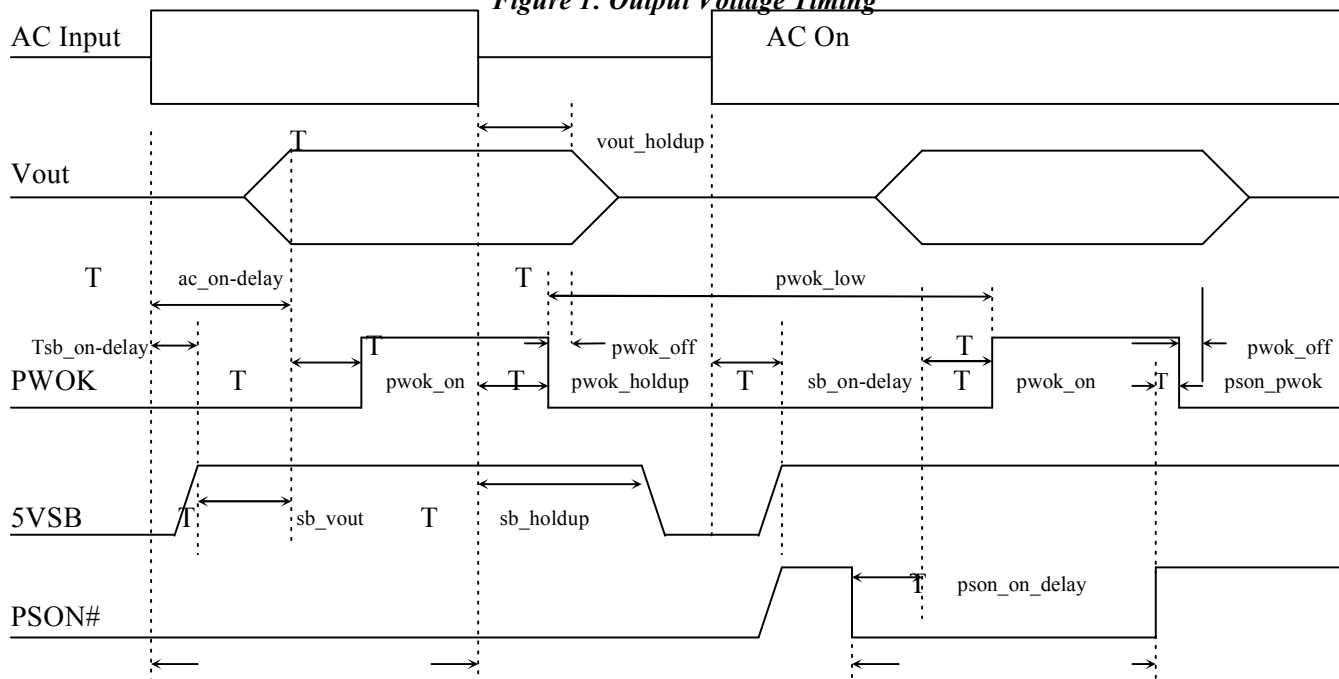
PSON turn on/off cycle



	Model No.:	Product Specification Document No.:
	NegoRack LTD	

Table 8: Timing Requirements

Item	Description	MIN	MAX	Units
Tvout_rise	Output voltage rise time from each main output	1	20	mS
	Output voltage rise time for the 5VSB out put	1	25	mS
Tvout_on	All main output must be within regulation of each other within this time.		50	mS
Tvout_off	All main output must leave regulation within this time		400	mS
Tsb_on-delay	Delay from AC being applied to 5VSB being within regulation.		1500	mS
Tac_on-delay	Delay from AC being applied to all output voltages being within regulation.		2500	mS

	Model No.:	Product Specification
	NR-DVR400-N	Document No.:
NegoRack LTD		

Tvout_holdup	Time all output voltage stay within regulation after loss of AC tested at 70% of maximum load.	12		mS
Tpwok_holdup	Delay from loss of AC to deassertion of PWOK tested at 70% of maximum load.	11		mS
Tpson_on_delay	Delay from PSON# active to output voltage within regulation limits.	5	400	mS
Tpson_pwok	Delay from PSON# deactive to PWOK being deasserted.		50	mS
Tpwok_on	Delay from output voltage within regulation limits to PWOK asserted at turn on.	100	500	mS
Tpwok_off	Delay from PWOK deasserted to output voltage dropping out of regulation limits measured at 70% of maximum load.	1		mS
Tpwok_low	Duration of PWOK being in the deasserted state during an off/on cycle using AC or the PSON# signal.	100		mS
Tsb_vout	Delay from 5VSB being in regulation to O/Ps being in regulation at AC turn on.	10	1000	mS

3.8 Hot Swap Requirements

Hot swapping a power supply is the process of inserting and extracting a power supply from an operating power system. During this process the output voltages shall remain within the limits with the capacitive load specified. The hot swap test must be conducted when the system is operating under static, dynamic, and zero loading conditions. The power supply can be hot swapped by the following method:

Extraction: The AC power will be disconnected from the power supply before the power supply is being extracted from the system. This could occur in standby mode or powered on mode.

Insertion: The AC power will be connected to the power supply after the supply is inserted into the system and the supply will power on into standby mode or powered on mode. In general, a failed (off by internal latch or external control) supply may be removed, then replaced with a good power supply, however, hot swap needs to work with operational as well as failed power supplies. The newly inserted power supply will get turned on in standby or Power On mode once inserted.

3.9 Efficiency

1. The power module efficiency shall at least come up to the 80plus sliver standard specified as 85%, 89%, and 85% minimum respectively measured at 20%, 50%, and 100% loads with 230VAC/60Hz input, 25C ambient temperature, and cooling fan power consumption excluded.

2. The overall power efficiency shall be in excess of 80% measured under the simultaneous conditions of 115V input and full load.

	Model No.:	Product Specification
	NR-DVR400-N	Document No.:
NegoRack LTD		

4. Protection Circuits

Protection circuits inside the power supply shall cause only the power supply's main outputs to shutdown. If the power supply latches off due to a protection circuit tripping, an AC cycle OFF for 15 sec and a PSON[#] cycle HIGH for 3 sec must be able to restart the power supply.

4.1 Over Current Protection (OCP)

The power supply shall have current limit to prevent main outputs from exceeding the values shown in *Table-Over Current Protection*. The power supply shall latch off if the current exceeds the limit.

Table 9: Over Current Protection

Voltage	Minimum of rated load	Maximum of rated load	Shutdown Mode
+3.3V, +5V, +12V	110%	150%	Latch Off

4.2 Over Voltage Protection (OVP)

The power supply is protected against over voltage due to an internal regulator failure. When an over voltage condition is detected, all DC outputs are disabled (except the 5VSB). The fault must be removed to restore the DC outputs. The limits are given in Table 11.

Table 10: Over Voltage Protection

Voltage	Minimum	Maximum	Shutdown Mode
+3.3V	+3.9V	+4.5V	Latch Off
+5V	+5.7V	+6.5V	Latch Off
+12V	+13.3V	+14.5V	Latch Off

4.3 Short Circuit Protection

The power supply shall shut down in latch off mode when the output voltage is short circuit (impedance less than 0.1ohm).

1) The power supply shall be no physical damage when +12V, +3.3V and +5V, is shorted to its DC return. 2) 5VSB shall be Auto Restart when short condition is removed.

4.4 No Load Operation

No damage or hazardous condition should occur with all the DC output connectors disconnected from the load. The power supply may latch into the shutdown state.

	Model No.:	Product Specification
	NR-DVR400-N	Document No.:
NegoRack LTD		

4.5 Over Temperature Protection In BP (OTP)

The power supply will shut down when an over temperature condition occurs. No damage shall be caused.

Ambient Temperature(Inlet Air)	Power Status
> 55°C	Warning
> 60°C	Power Shut off , but no damages
<55°C	Power Recovery

5. Environmental Requirements

5.1 Temperature

Operating Ambient, normal mode (Inlet air): 0°C ~ 50°C For 300W

Operating Ambient, normal mode (Inlet air): 0°C ~ 40°C For 400W Non-operating

Ambient:: -40°C ~ 70°C (-40°F~ 158°F)

5.2 Humidity

Operating: 20% ~ 90%RH non-condensing

Non-Operating: 5% ~ 95%RH non-condensing

5.3 Altitude

Operating: Sea level to 16,404 ft (5000 m)

Non Operating: Sea level to 40,000 ft (12192m)

5.4 Mechanical Shock

Non-Operating: 50 G Trapezoidal Wave, 11mS half sin wave. The shock is to be applied in each of the orthogonal axes.

5.5 Vibration (Non-Operating)

The power supply shall be subjected to a vibration test consisting of a 10 to 300 Hz sweep at a constant acceleration of 2.0g for duration of one (1) hour for each of the perpendicular axes X, Y and Z (0.1 octave/minute). The output voltages shall remain within specification.

	Model No.:	Product Specification
	NR-DVR400-N	Document No.:
NegoRack LTD		

5.6

Electromagnetic Compatibility *Table 11:* *EMC Requirements*

Electromagnetic Interference	FCC CFR Title 47 Part 15 Sub Part B EN55022/EN55024	Conducted A Class -6dB Radiated A Class -6dB
Harmonics	EN 61000-3-2 Class A	
Flicker	EN 61000-3-3	
ESD Susceptibility	IEC 61000-4-2	±8KV by Air, ±4KV by Contact, Performance Criteria B
Radiated Susceptibility	IEC 61000-4-3	80MHz~1000MHz (3V/m) Amplitude 80% AM 1KHz, Criteria A
EFT/Burst	IEC 61000-4-4	Repetition Rate 5KHz, AC port: 1KV, DC: 0.5 KV, Performance Criteria B
Surge Voltage	IEC 61000-4-5	Line-to-Line: 1KV Line-to-Ground: 2KV, Performance Criteria B
Conducted Susceptibility	IEC 61000-4-6	0.15MHz~80MHz 3V/m Amplitude 80% AM 1KHz, Performance Criteria A
Power frequency magnetic field	IEC 61000-4-8	50 Hz, 1A/m Performance Criteria A
Voltage Dips and Interruptions	IEC 61000-4-11	>95%(Voltage Dips) 30%(Voltage Dips) 95%(Voltage Interruption)
		Criteria B Criteria C Criteria C

5.7 Safety Agency Requirements

This power supply is designed to meet the following safety :

	Model No.:	Product Specification
	NR-DVR400-N	Document No.:
NegoRack LTD		

Table 12: Product Safety

Product Safety:	<ul style="list-style-type: none"> • CB: IEC 60950-1:2005 (2nd Edition); Am 2:2013 • TUV: EN60950-1/A2:2013 • UL: UL60950-1, 2nd Edition, 2014-10-14 • CCC: GB4943.1-2011 GB9254-2008 GB17625.1-2012 • BSMI : CNS14336-1 (99). CNS13438(95)
------------------------	--

6 Reliability

6.1 Mean Time Between Failures (MTBF)

The MTBF of the power module in PSU shall be calculated utilizing the Part-Stress Analysis method of MIL217F. The calculated MTBF of the power supply shall be greater than 100,000 hours under the following conditions:

Full rated load; 120V AC input; Ground Benign; 25°C

7. Mechanical Overview

Dimension: 85mm(W) x 84mm(H) x 217mm(D)

Weight: 3.4kg

7.1 Input AC Connector

The AC inlet is a IEC320 C14 type 3pin connector

8. PMBUS COMMAND CODE SUMMARY (For PDB):

Table 13: Support Command Code Table

Command Code	Command Name	SMBus Transaction Type	Number of Data Bytes	Data Format
03h	CLEAR_FAULTS	Send Byte	0	-
19h	CAPABILITY (1)	Read Byte	1	Byte
20h	VOUT_MODE (1)	Read Byte	1	Byte
1Ah	QUERY (1)	Read Byte	1	Byte
79h	STATUS_WORD	Read Word	2	Word
7Ah	STATUS_12V_VOUT	Read Byte	1	Byte
7Bh	STATUS_12V_IOUT	Read Byte	1	Byte
7Dh	STATUS_TEMPERATURE	Read Byte	1	Byte
80h	STATUS_MFR_SPECIFIC	Read Byte	1	Byte
8Bh	READ_12V_VOUT	Read Word	2	Linear Vout

 NegoRack LTD	Model No.: NR-DVR400-N	Product Specification
		Document No.:

8Ch	READ_12V_IOUT	Read Word	2	Linear
8Dh	READ_TEMPERATURE_1 (2)	Read Word	2	Linear
96h	READ_12V_POUT	Read Word	2	Linear
99h	MFR_ID	Block Read	6	ASCII
9Ah	MFR_MODEL	Block Read	9	ASCII
9Bh	MFR_REVISION	Block Read	2	ASCII
9Eh	MFR_SERIAL	Block Read	12	ASCII
A7h	MFR_POUT_MAX	Read Word	2	Linear
A8h	MFR_TAMBIENT_MAX	Read Word	2	Linear
B0h	STATUS_PDB	Read Byte	1	Byte
E0h	READ_3V3_VOUT	Read Word	2	Linear Vout
E1h	READ_3V3_IOUT	Read Word	2	Linear
E2h	READ_3V3_POUT	Read Word	2	Linear
E3h	READ_5V_VOUT	Read Word	2	Linear Vout
E4h	READ_5V_IOUT	Read Word	2	Linear
E5h	READ_5V_POUT	Read Word	2	Linear

Note : READ_TEMPERATURE_1, should provide the PDB inlet temperature

Table 14: Contents in 79h (STATUS_WORD) Command Code

Byte	Bit Number	Status Bit Name	Meaning
Low	7	Reserved	Return=0
	6	OFF	The Unit Main Power OFF = 1 ;Power ON = 0;
	5	+12V_OV_FAULT	An output overvoltage fault has occurred = 1 ; Normal = 0
	4	+12V_OC_FAULT	An output overcurrent fault has occurred = 1 ; Normal = 0
	3	Reserved	Return=0
	2	Temperature	A Temperature fault or warning has occurred = 1 ; Normal = 0
	[1:0]	Reserved	Return=0

 NegoRack LTD	Model No.:	Product Specification
	NR-DVR400-N	Document No.:

High	7	+12V_VOUT	An output voltage fault or warning has occurred = 1 ; Normal = 0
	6	+12V_IOUT	An output current fault or warning has occurred = 1 ; Normal = 0
	5	Reserved	Return=0
	4	MFR_SPECIFIC	Any Bits of Byte Action (See Table 18)
	3	POWER_GOOD#	The POWER_GOOD signal is OK = 0 ; FAIL = 1
	[2:0]	Reserved	Return=0

Table 15 : Contents in 7Ah (STATUS_VOUT)Command Code

Bit Number	Status Bit Name	Meaning
7	+12V_OV_FAULT	VOUT > 14.5V = 1 ; Normal = 0
6	+12V_OV_WARNING	VOUT > 13.2V = 1 ; Normal = 0
5	+12V_UV_WARNING	VOUT < 10.8V = 1 ; Normal = 0
4	+12V_UV_FAULT	VOUT < 8.4V = 1 ; Normal = 0
[3:0]	Reserved	Return=0

Table 16: Contents in 7Bh (STATUS_IOUT)Command Code

Bit Number	Status Bit Name	Meaning
7	+12V_OC_FAULT	12V_IOUT > Max Current of 130% = 1 ; Normal = 0
6	Reserved	Return=0
5	+12V_OC_WARNING	12V_IOUT > Max Current of 110%@10ms = 1 ; Normal = 0
[4:0]	Reserved	Return=0

Table 17: Contents in 7Dh (STATUS_TEMPERATURE)Command Code

Bit Number	Status Bit Name	Meaning
[7:4]	Reserved	Return=0
3	Ambient_OT_FAULT	Ambient temperature $\geq 60^{\circ}\text{C}$ = 1 ; Normal = 0
2	Ambient_OT_WARNING	Ambient temperature $\geq 55^{\circ}\text{C}$ = 1 ; Normal = 0
[1:0]	Reserved	Return=0

Table 18 : Contents in 80h (STATUS_MFR_SPECIFIC)Command Code

Bit Number	Status Bit Name	Meaning
7	3V3_UV_FAULT	VOUT < 2.8V = 1 ; Normal = 0

	Model No.:	Product Specification
	NegoRack LTD	
		Document No.:

6	3V3_OV_FAULT	VOUT > 4.5V = 1 ; Normal = 0
5	5V_UV_FAULT	VOUT < 3.5V = 1 ; Normal = 0
4	5V_OV_FAULT	VOUT > 6.5V = 1 ; Normal = 0
3	3V3_IOUT_OC_FAULT	3V3_IOUT > Max Current of 130% = 1 ; Normal = 0
2	3V3_IOUT_OC_WARNING	3V3_IOUT > Max Current of 110% = 1 ; Normal = 0
1	5V_IOUT_OC_FAULT	5V_IOUT > Max Current of 130% = 1 ; Normal = 0
0	5V_IOUT_OC_WARNING	5V_IOUT > Max Current of 110% = 1 ; Normal = 0

Table 19 : Contents in B0h (STATUS_PDB) Command Code

Bit Number	Status Bit Name	Meaning
7	PSU1_FAULT	PSU1 FAULT = 1 ; Normal = 0
6	PSU2_FAULT	PSU2 FAULT = 1 ; Normal = 0
5	PSU1_PLUG_STATUS	PSU1 PLUG-OUT = 1 ; PLUG-IN = 0
4	PSU2_PLUG_STATUS	PSU2 PLUG-OUT = 1 ; PLUG-IN = 0
3	POWER_GOOD#	POWER_GOOD signal is FAIL = 1 ; OK = 0
2	PSON#	PSON#_H = 1 ; PSON#_L = 0 ;
[1:0]	Reserved	Return=0

Table 20: MFR Meaning (For 400w PDB)

Command Code	Command Name	Meaning
99h	MFR_ID	NEGORACK
9Ah	MFR_MODEL	NR-DVR400-N
9Bh	MFR_REVISION	A0 ~ Z9
9Eh	MFR_SERIAL	Code = 12 (ex. T201XXG00001)
A7h	MFR_POUT_MAX	400 (W)
A8h	MFR_TAMBIENT_MAX	40 (°C)

Table 21: Pmbus Address Set

PDB address	
MCU Device	BE

9 . LED behaviors:

	Model No.:	Product Specification
	NR-DVR400-N	Document No.:
NegoRack LTD		

Table 22 :LED Behaviors

Power Supply Condition	LED State
Normal	GREEN
No AC power to all power supplies	OFF
Power Fail	RED

10. Signals from Wire Harness

Table 23: Signals from Wire Harness (PFD Cable)

Power Supply Status	Signal Type
Works Normally	High
Power Module Not Inserted or Pulled Out	Low
Power Fail	Low
Fan Fail	Low

Note: 1) Alarm reset is used to clear power fail status by shorting circuit activities.
2) Buzzer shall alarm if signal goes low.

Appendix I. Data Format Description

The Linear Data Format is typically used for commanding and reporting the parameters such as (but not only) the following:

- Output Current (A)
- Output Power(W)
- Temperature(□) • Any Warning Limit

The Linear Data Format is a two byte value with:

An 11 bit, two’s complement mantissa and a 5 bit, two’s complement exponent (scaling factor).

The format of the two data bytes is illustrated in Figure

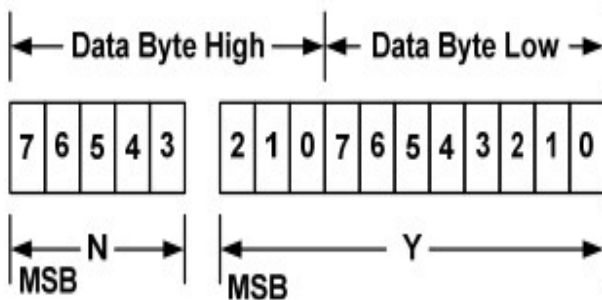

The relation between Y, N and the “real world” value is:

$$X = Y \cdot 2^N$$

Where, as described above:

X is the “real world” value;

Y is an 11 bit, two’s complement integer; and N

is a 5 bit, two’s complement integer.

 NegoRack LTD	Model No.:	Product Specification
	NR-DVR400-N	Document No.:

Devices that use the Linear format must accept and be able to process any value of N.

NegoRack®	Model No.: NR-DVR400-N	Product Specification
NegoRack LTD		Document No.: